

Quattro

Inspire your eyes

mark'ennovy



Quattro is individually manufactured with the material mark'ennovy was founded on, GMA-49. It is our classic line of lenses produced with the most advanced technology for mark'ennovy's most experienced contact lens users.



CHARACTERISTICS

More Custom Individually made for each eye in multiple designs.

More Comfort Proven Hydrogel (49%).

Vision Type Classic—vision satisfaction you have grown to trust.

TECHNICAL SPECIFICATIONS

MATERIAL	Hydrogel Filcon I 1 49%		
Dk	15		
HANDLING TINT	Yes		
UV BLOCKING	Yes		
		Parameter Range	Steps
DIAMETER (mm)	⊙ ⊙	13.00 and 14.50	
	⊙	14.00 and 14.50	
BASE CURVE* (mm)	⊙ ⊙ ⊙	7.70 to 9.80	0.30
	∅ 13.00 ⊙ ⊙	7.10 to 9.20	0.30
SPHERE* (D)	⊙ ⊙	+30.00 to -30.00	0.25
	⊙	+8.00 to -12.00	0.25
CYLINDER* (D)	⊙	-0.75 to -8.00	0.25
AXES (°)	⊙	All	5°
ADDITION (D)	⊙	A – B – C	
MULTIFOCAL – DESIGN	⊙	CD – CN	

*Wider range of parameters available for Conventional lenses. For more information contact our Customer Service Department.

QUATTRO LENS DESIGN

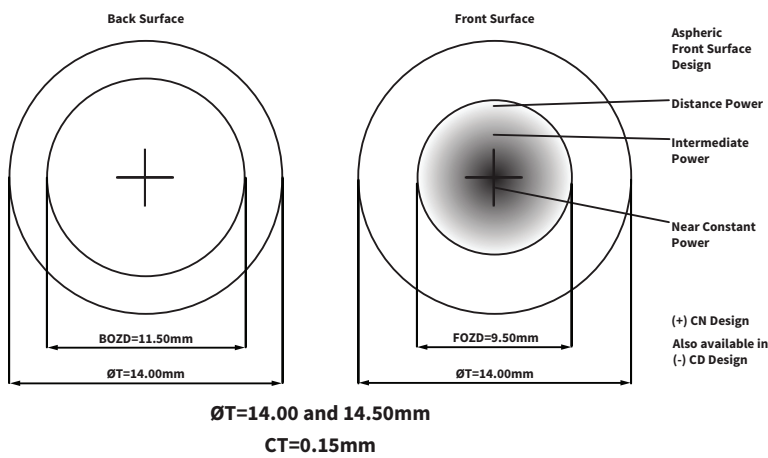
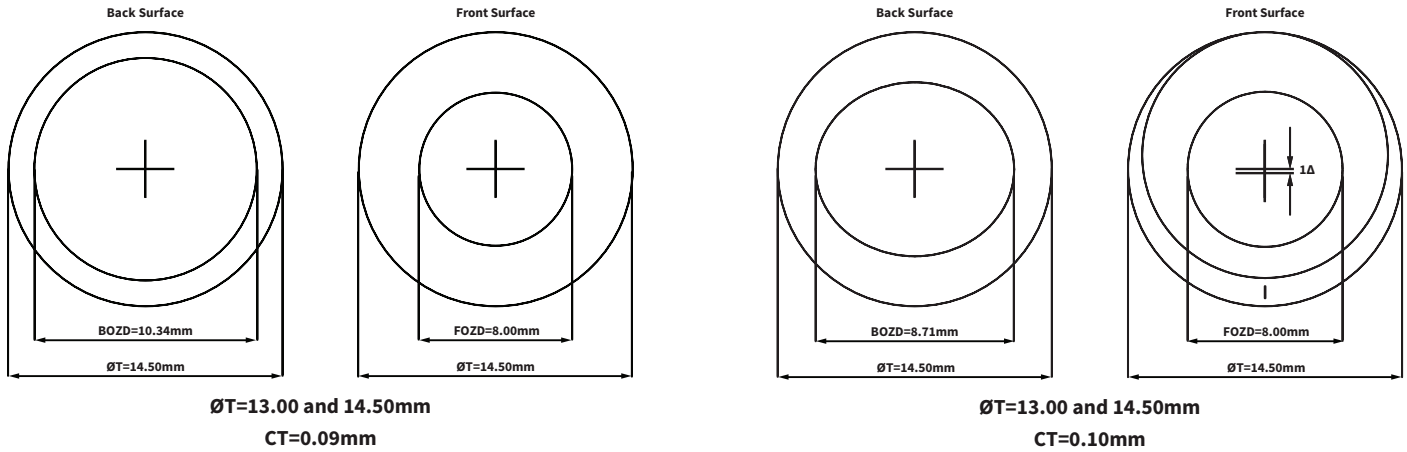

Lens design parameters may change depending on the power.

- *Based on Sph -3.00
- **Based on Sph -3.00 Cyl -1.25
- ***Based on Sph -3.00 Add B

Are you an Eye Care Professional?

Order your contact lenses at www.markennoy.com through **MyEnnoy**, or contact our Customer Service Department to begin working together.

CD & CN			
Myopia		Hypermetropia	
CD Design for Both Eyes		CN Design for Both Eyes	

Customer Service:
 T. 0800 328 0610 F. 0800 328 0649
International Phone:
 T. +34 916 496 123
 E. mkservices@markennoy.com

+Information
www.markennoy.com

Inspire your eyes

markennoy